

Вештица лети на својој метли.  
Заокружи правилно окренута слова и  
сазнаћеш њено име.

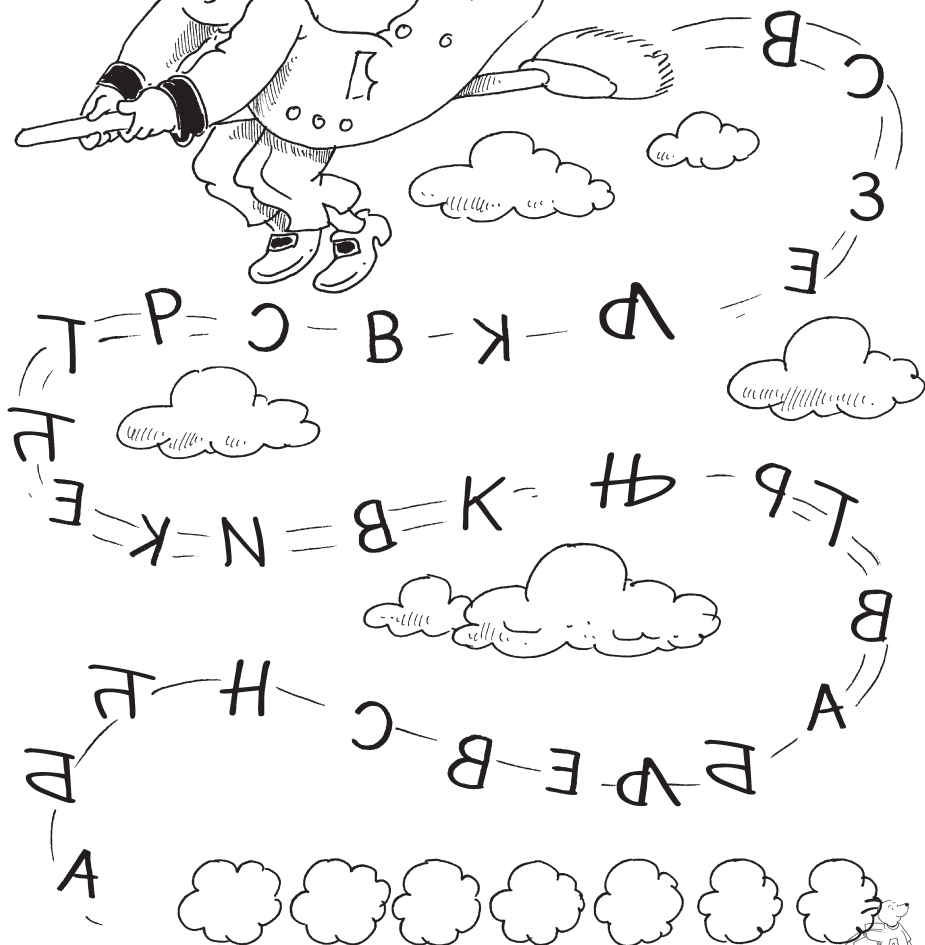

# Решете

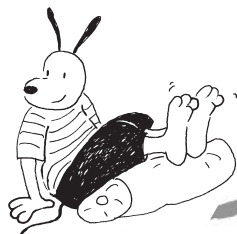
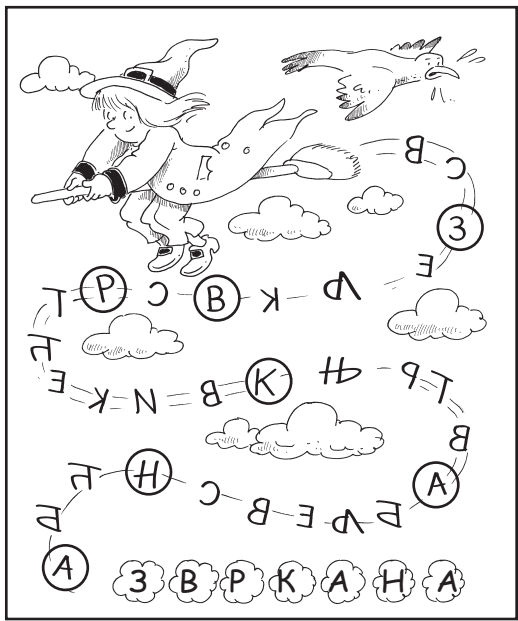

Вештичица се зове ЗВРКАНА.

Витез Седобради тражи свој штит и  
мач за турнир. Препознајеш ли његово  
оружје? Заокружи тражене предмете.

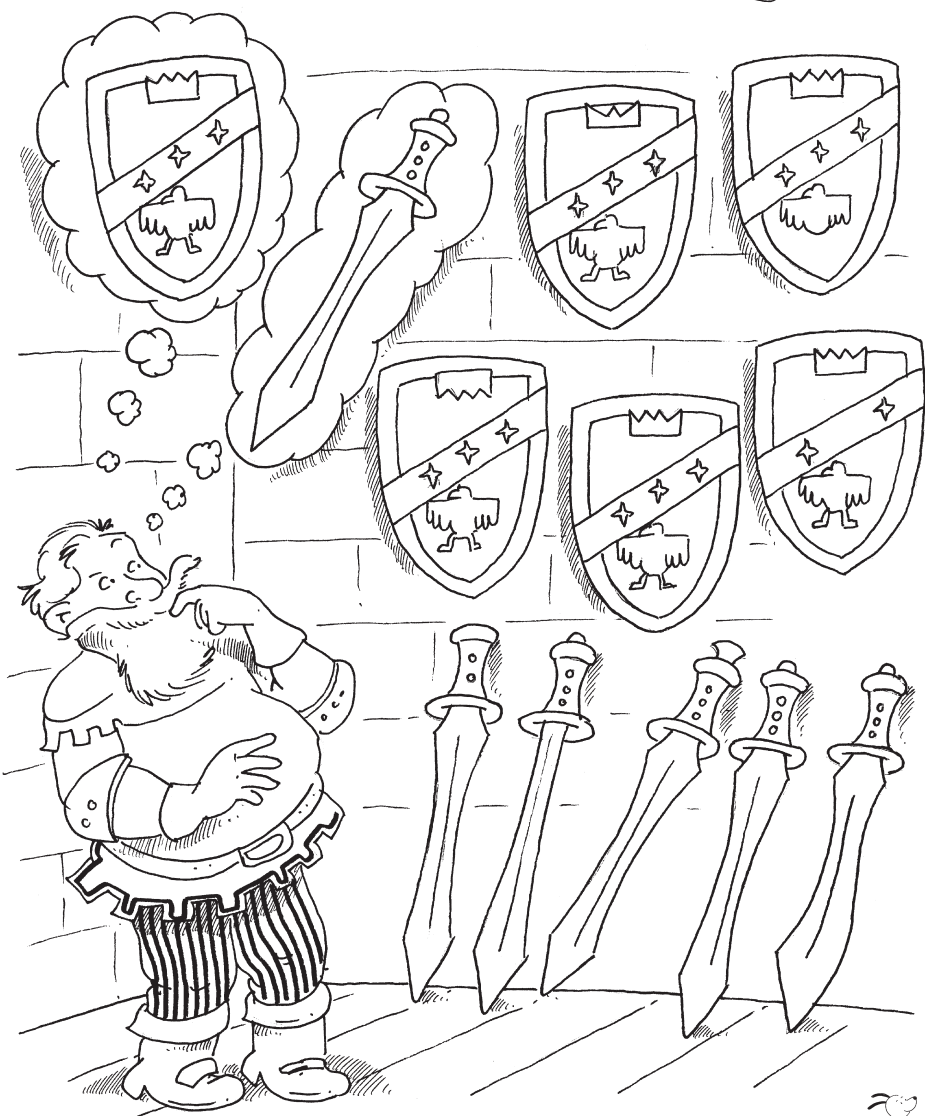
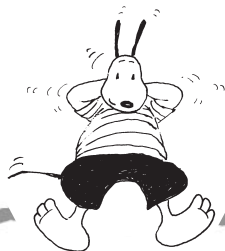

# Pellele

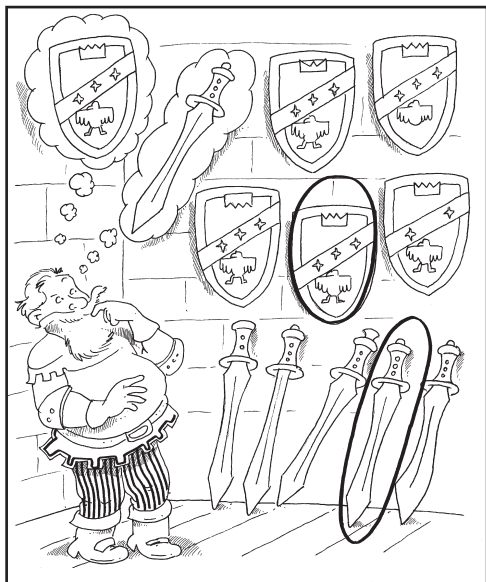

Добар духић фотографисао је замак и жели да стави слике у одговарајуће оквире. Која слика одговара ком раму? Поређај их правилно и сазнаћеш како се духић зове.

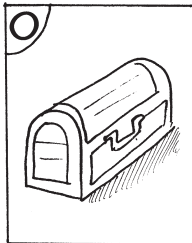
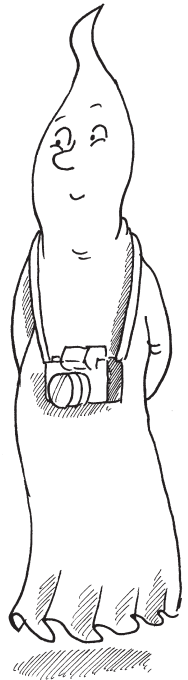
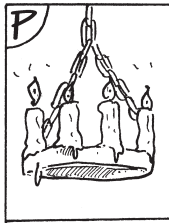
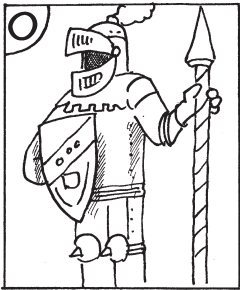
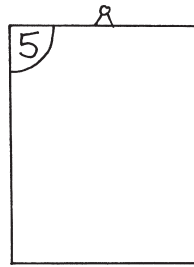
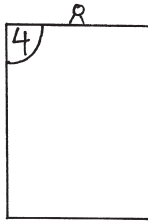
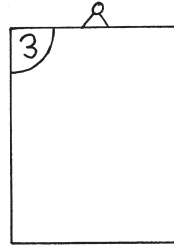
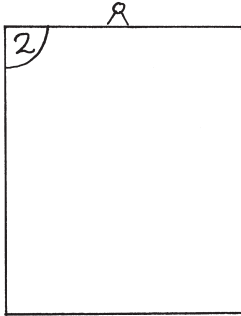
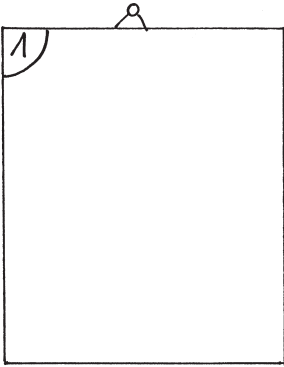

1	2	3	4	5



# Решете

The puzzle consists of a 5x5 grid. The top row contains five empty boxes numbered 1 to 5. Below them are five illustrated boxes: 1. A knight in armor holding a sword. 2. A church with candles. 3. A castle. 4. A mug. 5. A treasure chest. A cartoon ghost with a camera stands to the right of the grid. Arrows point from the knight to box 1, from the church to box 2, from the castle to box 3, from the mug to box 4, and from the treasure chest to box 5. Below the grid is a 1x5 grid with Cyrillic letters: Б О Р К О.

1	2	3	4	5
Б	О	Р	К	О

Добар духић се зове БОРКО.

Једна просторија у замку је закључана.  
Повежи сваки кључ са одговарајућом  
бравом и сазнаћеш која просторија  
замка је најстроже чувана.

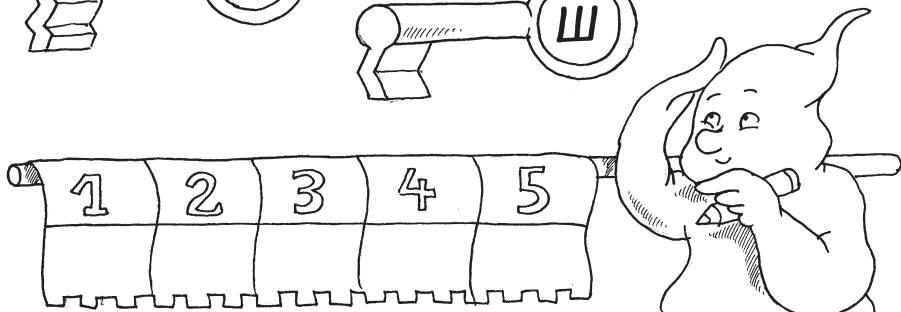
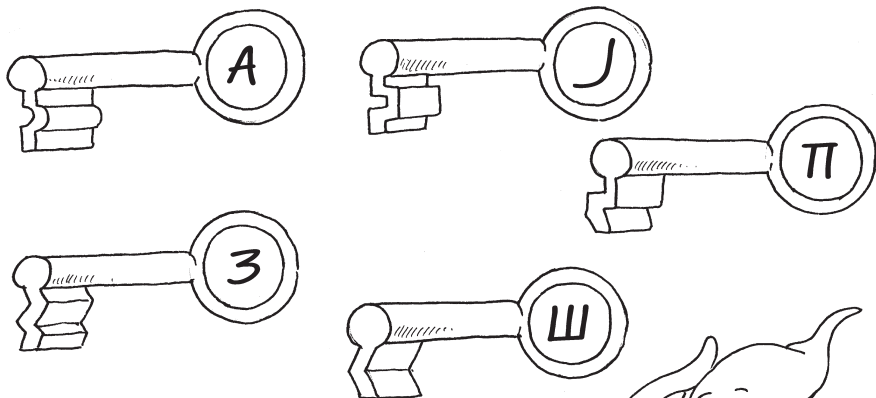
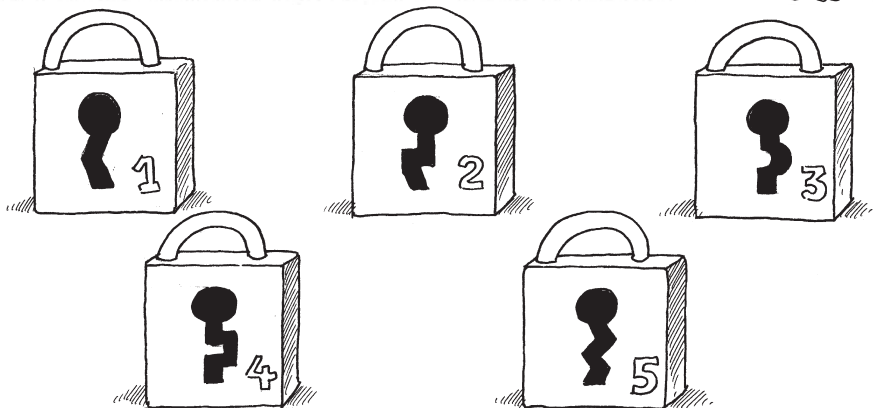

# Решете

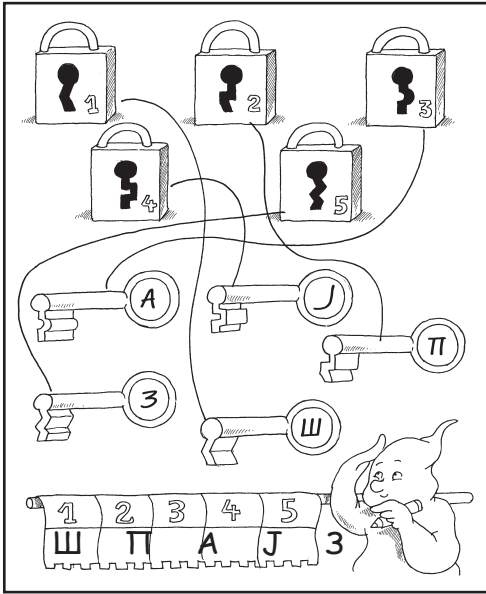

ШПАЈЗ мора бити најстроже  
чуван због слаткиша.